

LEDit Lighting Co., Ltd.

Add: Yinuo Industrial Park, Intersection of No.2 Circle Road and Qixin Road,
Xintan Town, Shunde District, Foshan, China 528325

Tel: +86-757-27785252 Fax: +86-757-27785252

Email: sales@leditlighting.com www.leditlighting.com



H351-S18/24/36-RGB SPECIFICATION

Ver 1.0

Wall Washer H Series:

351-S18/24/36-RGB

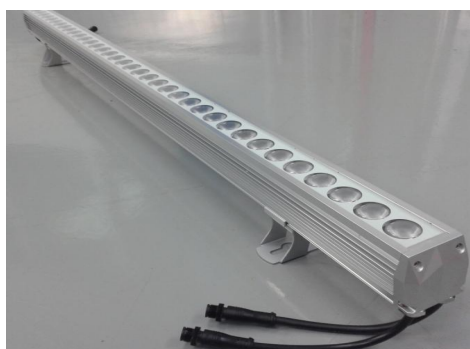

Detail Information:

H351-S18/24/36-RGB is designed for high-end decoration. It adopts 18/24/36pcs high-power LEDs, using aluminum alloy completely waterproof design with IP rate IP66. It is easy and reliable to install. The beam angle is optional as 12°x 48°/10°x 60° or others.

Each Wall Washer can be used as a separate 8bit color pixel (The segment also can be customized). Accompanied by our own lighting managing tools and control system, it can reach any decoration requirement, which is widely applied to building, bridge, stage, pub, etc.

Applicable Environment:

- indoor
- outdoor

PARAMETER:

Basic Parameter	
Model	H351-S18/24/36 RGB
Color Grey	RGB 256 grey scale each, 16777216 kinds of color in total
Light Source	18 / 24 / 36pcs High Power LED
LED Chip	Epistar/ Cree
Wave Length	625nm±5nm, 525nm±5nm, 470nm±5nm
Lifetime	50,000Hours
Material	Tempered glass cover / Aluminum Alloy
Drive Mode	DMX512/Always on

LEDit Lighting Co., Ltd.

Add: Yinuo Industrial Park, Intersection of No.2 Circle Road and Qixin Road,
Xintan Town, Shunde District, Foshan, China 528325

Tel: +86-757-27785252 Fax: +86-757-27785252

Email: sales@leditlighting.com www.leditlighting.com



Weight	3.0kg/pc
Environment Parameter	
working Temperature	-35°C~50°C
Storage Temperature	-40\5°C~80°C
Ingress Protection	IP66 and above
Controller	
controller	SS main controller
Sub-controller	SS Sub controller (8 port output, each output can support 512pixels)
Electricity	
Working Input Voltage	DC 24V / AC 220V
Max Power Consumption	18W/ 24W/ 36W/pcs
Average Power Consumption	10.8W / 14.4W / 21.6W/pcs
Performance	
Brightness	70 lm/w
Beam Angle	12° x 48° / 10° x 60°

DIMENSION (mm)

LEDit Lighting Co., Ltd.

Add: Yinuo Industrial Park, Intersection of No.2 Circle Road and Qixin Road,
Xintan Town, Shunde District, Foshan, China 528325

Tel: +86-757-27785252 Fax: +86-757-27785252

Email: sales@leditlighting.com www.leditlighting.com

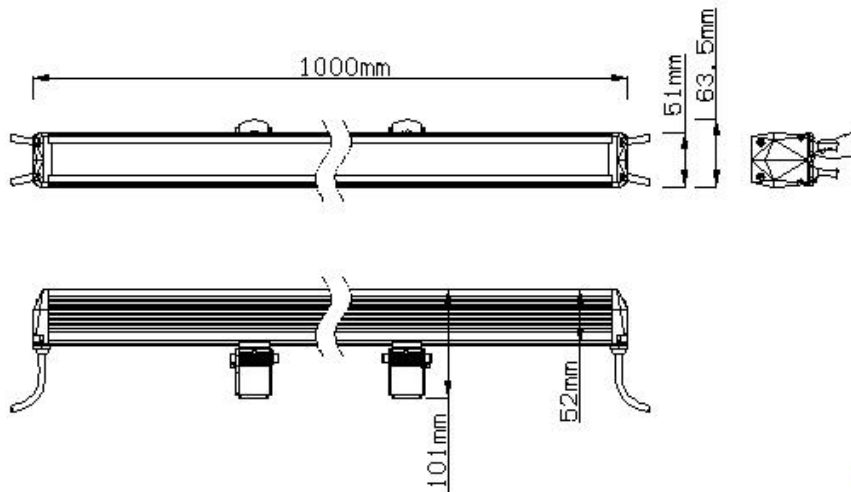

FIXED INSTALLATION

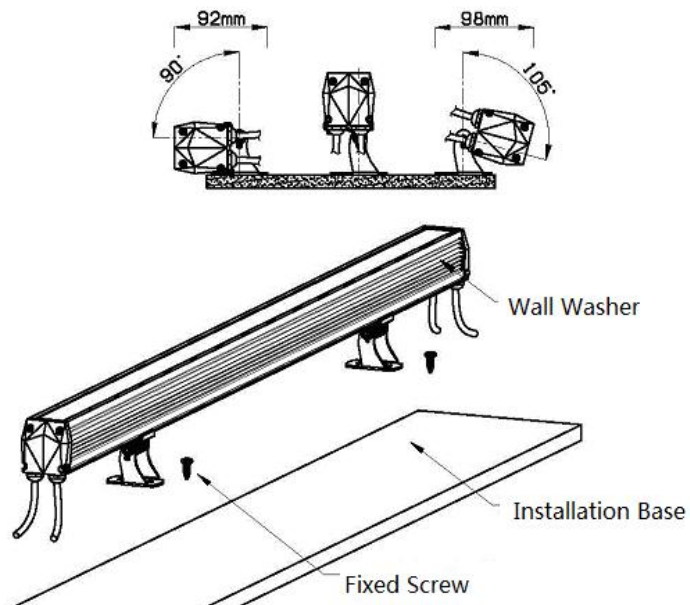

Distribution Curve

LEDit Lighting Co., Ltd.

Add: Yinuo Industrial Park, Intersection of No.2 Circle Road and Qixin Road,
Xintan Town, Shunde District, Foshan, China 528325

Tel: +86-757-27785252 Fax: +86-757-27785252

Email: sales@leditlighting.com www.leditlighting.com

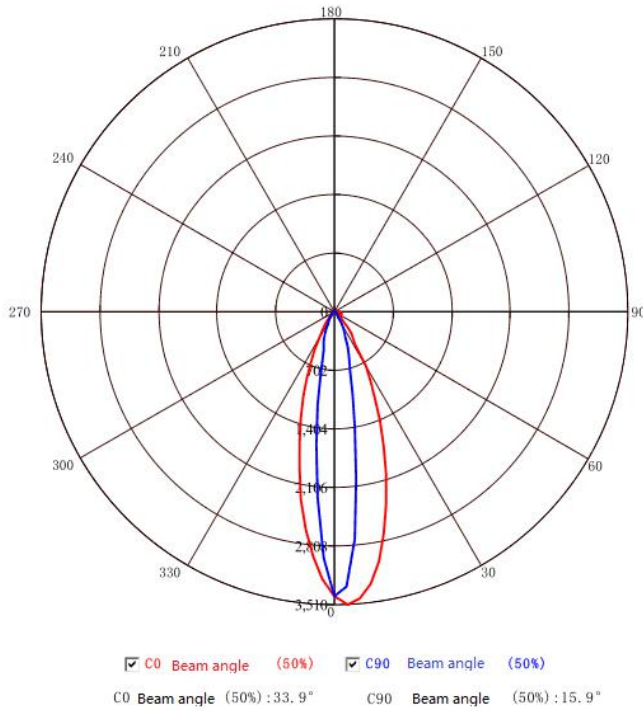

SYSTEM CONFIGURATION

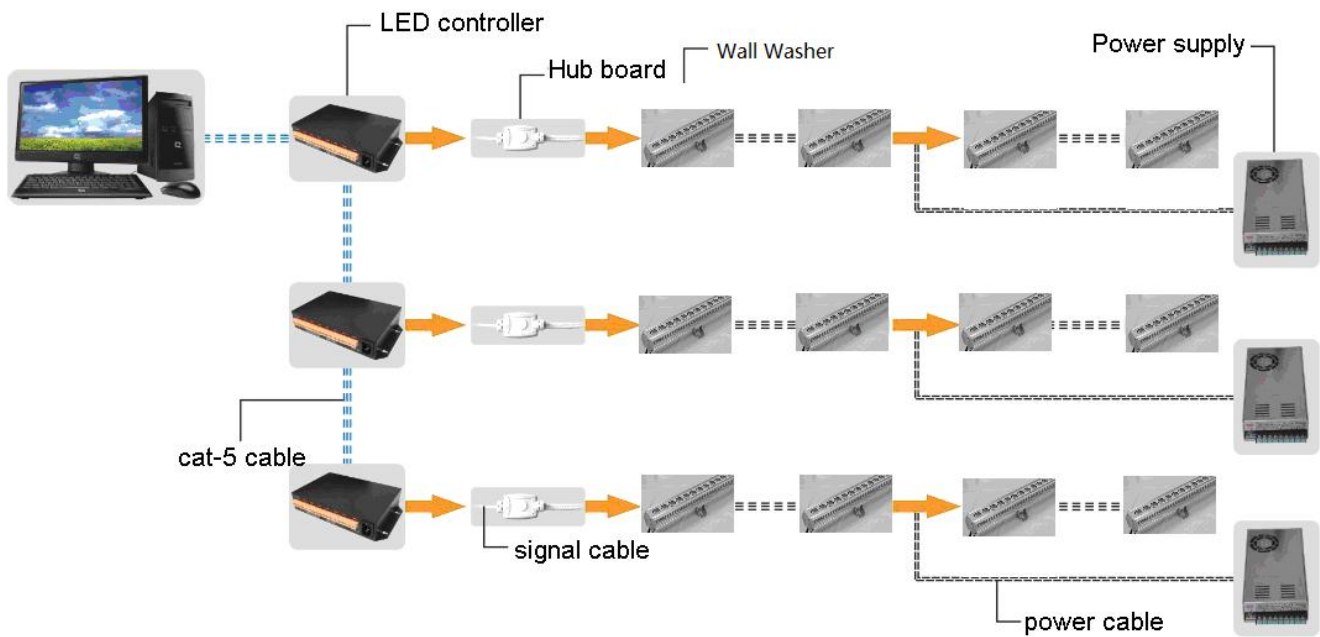

LEDit Lighting Co., Ltd.

Add: Yinuo Industrial Park, Intersection of No.2 Circle Road and Qixin Road,
Xintan Town, Shunde District, Foshan, China 528325

Tel: +86-757-27785252 Fax: +86-757-27785252

Email: sales@leditlighting.com www.leditlighting.com



Available Models:

Modle No.	Voltage	Power	Color	Source	Control	Lux
351-S18-W	AC220V	18W	White	18W	Always on	1800(lm)
351-S18-RGB-D	AC220V	18W	RGB	6R6G6B	DMX512	1260(lm)
351-S24-W	AC220V	24W	White	24W	Always on	2400(lm)
351-S24-RGB-D	AC220V	24W	RGB	8R8G8B	DMX512	1680(lm)
351-S36-W	AC220V	36W	White	36W	Always on	3600(lm)
351-S36-RGB-D	AC220V	36W	RGB	12R12G12B	DMX512	2520(lm)